

the Effect of Single-Phase Dispersed Generation Sources in Distribution Network for Correction of Voltage Imbalance

Mustafa Okati*, Mohammadreza Aminian

Received: 25 December 2018 / Received in revised form: 14 April 2019, Accepted: 03 May 2019, Published online: 25 May 2019
© Biochemical Technology Society 2014-2019
© Sevas Educational Society 2008

Abstract

Now a day we face growth of load and dispersion of consumers in electricity networks which have made long distance between generators and consumers in wide electric network because of providing primary conditions of power plants (primary fuel, the appropriation of geographical location to the kind of generation, eliminating environmental pollution from residential places and ...). This leads to a lot of loss during network transition and reduction of network reliability. Therefore, in recent years, use of dispersed generators for making generators and consumers closer together and reducing losses in network has been investigated. In this case, the renewable energy sources were center of attention (solar energy, wind, water, and ...). In this research, we investigate the effect of single phase dispersed generation sources on distribution network for correcting the voltage imbalance. In this way, a distribution network is simulated in MATLAB software and imbalance is made by an asymmetric load and a gravitational search algorithm is used for correcting voltage loss between the phases of circuit for determining the best response of control circuit of dispersed generation source. Finally, it can be concluded from the output of the circuit that the presence of dispersed generation sources is in continuous mode and it was able to correct the imbalance of voltage significantly.

Keywords: Dispersed Generation Sources, Gravitational Search Algorithm, Voltage Imbalance, Distribution Network.

Introduction

It is a few years that the case of loss of energy is the center of attention of electricity experts because of hundred millions of dollars cost in electricity industry annually and its consequences and technically and financial costs were of interest and it has been analyzed widely and the practical ways of reducing it is cleared. One of the reasons of energy loss is imbalance in load distribution; by adjusting it, you can take positive steps to reduce losses and optimize the network. A part of electric losses is appeared because of load imbalance. Basically, in distribution networks which have variety of industrial, residual, and commercial loads and a big portion belongs to single phase loads so reaching to balance is very difficult and almost impossible. Imbalance is one of the prevalent problems of distribution networks. Load imbalance exists in two dynamic and static forms. Static imbalance is related to fixed impedance loads which always have specific and definite manner. But dynamic imbalance is related to compound loads' collective manner. The load of low pressure distribution network feeders is collective and compound type which leads to imbalance of load and lines current in phases because of stochastic and asynchronous behavior of single phase users and none uniform distribution of them between different phases. Load and current imbalance have bad effects on network behavior and other equipments and consumers of network. Loss increase, null point of network's getting electrified; electric motors' and transformers' getting warm, and saturation of magnetic cores are some examples of destructive effects of load imbalance. Moreover, existence of nonlinear loads results in harmonic production and decrease of power factor. In the past, there was two ways for decreasing the voltage imbalance: load balance method and phase balance method. In load

balance method, active filters compensate load imbalance meanwhile injecting appropriate currents and in phase balance method, the voltage gets balanced in every point of feeder. Changing the phases is a usual way for balancing the phase and the main purpose is finding convenient displacement pattern for balancing a feeder with least cost. These two methods have some disadvantages which are discussed below. In this research we investigate new way based on use of single phase dispersed generation sources.

Mustafa Okati*

Department of Electrical Engineering, Zabol Branch, Islamic Azad University, Zabol, Iran.

Mohammadreza Aminian

Yong Researchers and Elit Club, Kerman Branch, Islamic Azad University, Kerman, Iran.

Methodology

Now days, by growth of problems and importance of the velocity of finding the answers, the classic methods are not suitable for solving the most of the problems. Therefore, using the Heuristic Search Algorithms has had considerable growth. The Heuristic Search Algorithms are the algorithms which are created inspired by physical and biological process and nature and most of them act in collective way. The behavior of members leads to system organization from the inside by creating some characteristics like positive feedback, negative feedback, balance between two exploration, and productivity and multitasking interactions which is called self-organization. In demographic methods interactions and information exchange between the members are done by through different ways. Among these algorithm the genetic algorithm (Tang et al., 2014) is inspired by science of inheritance and evolution (1975), the simulated annealing algorithm is inspired by thermodynamic observations (1983) (Kirkpatrick et al., 2009), immune algorithm is the simulation of human immune system (1986) (Farmer et al., 2012), the ant colony optimization algorithm is the simulation of the behavior of the ants which are looking for food (1991) (Dorigo, 2007), and the particle swarm optimization algorithm is by imitation of the behavior of birds (Kennedy & Eberhart, 2013). In the same vein, the gravitational optimization algorithm is defined with other name calling gravitational search algorithm (Rashedi et al., 2009; Rahsedi & abadi pur, 2007). This algorithm is provided inspired by the concepts of mass and gravitational force and by simulating the existing rules in nature which is used in this research for optimizing the control factors (PID: Proportional, Integral, and Derivative).

Gravitational search algorithm

In GSA algorithm the optimization is done by gravity and motion rule in an artificial system with discrete time (Rahsedi & abadi pur, 2007). The environment of the system is the problem definition zone. Based on gravity rule each mass understand the location and condition of other masses by gravity rule. Therefore, this force can be used as a tool for exchanging the information. The designed optimizing finder can be used for solving an optimizing problem in which each answer of problem can be defined as a location of a point in space and the amount of its resemblance with other answers of problem can be defined in form of a distance. The amount of masses is determined by attention to target function.

In the first step the space of system is determined. The environment is consisting of a multidimensional coordination system in the space of problem definition. Each point of space is one answer of problem. The searching factors are a set of masses and each mass has three properties:

- A) The condition of mass
- B) Gravitational mass
- C) Inertia mass

The masses above are retrieved from the concepts of active gravitational mass and inertia mass in physics. In physics, the active gravitational mass is a criterion for the intense of gravitational force around a body and the inertia mass is a criterion for the resistance of body against the motion. These two characteristics can be unequal unlike reality and the amount of them is determined based on fitness of each mass. The location of mass is a point in space which is an answer of problem. After forming the system the rules of it get cleared. We suppose that only there are gravity and motion rules. The general form of these rules is almost like nature rules and is defined as below.

Steps of gravitational search algorithm

1. Factors start to move

By start the location of n factors which are chosen randomly is determined by

$$X_i = (x_i^1, \dots, x_i^d, \dots, x_i^n), \text{ for } i = 1, 2, \dots, N \quad (1)$$

2. Evolution and determination of situation for each factor

Doing the evolution of situation for all of the factors and finding the best and worst location for decreasing the optimization problems based on following equation

$$Best(t) = \min_{j \in \{1, \dots, N\}} fit_j(t) \quad (2)$$

$$\text{worst}(t) = \max_{j \in \{1, \dots, N\}} \text{fit}_j(t) \quad (3)$$

3. Calculating the gravitational constant G, the determined inertia of gravitational constant G in t by equation (17-3)

$$G(t) = G_o e^{\left(\frac{xt}{T}\right)} \quad (4)$$

4. Calculation of the mass of each factor, finding the gravitational mass and inertia mass of each of the factors in t inertia in

$$M_{ai} = M_{pi} = M_{ii} = M_i, i = 1, 2, \dots, N \quad (5)$$

$$M_i(t) = \frac{\text{fit}_i(t) - \text{worst}_i(t)}{\text{best}(t) - \text{worst}(t)}$$

$$M_i(t) = \frac{m_i(t)}{\sum_{j=1}^N m_j(t)}$$

5. Calculating the acceleration of each factor

$$a_i^d(t) = F_i^d(t) / M_i(t) \quad (6)$$

$f_t^d(t)$ is the sum of the acting force on factor i which is calculated by equation 8

$$F_i^d(t) = \sum_{j \in k \text{ best } j^* i} \text{rand}_j F_{ij}^d(t) \quad (7)$$

6. Updating the velocity and location of each factor by

$$V_i^d(t+1) = \text{rand}_i \times V_i^d(t) + a_j^d(t) \quad (8)$$

$$X_i^d(t+1) = X_i^d(t) + V_j^d(t+1) \quad (9)$$

Repeating the 2 to 6 steps up to the inertia reach to their maximum. Return of the best calculated state in final inertia as the general state of problem and convenient location of each factor in determined dimension as the general solve of the problem.

Modeling of the distribution network

In electricity distribution networks the four wires three phase system is used for conveying the electricity to subscribe. Figure (1) shows the circuit diagram of sample network. The voltage of this network is 20.3807 kv. In residential and commercial distribution networks most of the loads are single phase and the loads are connected between one of the null and phase wires. The assumptions which are investigated later are:

- a) The loads of distribution network are considered in centralized form
- b) The equivalent distribution network circuit toward the Top-handed network (power grid) is a venin circuit.
- c) The voltage of source in the venin equivalent circuit is three phases and symmetric.
- d) The impedance of lines and phase are considered the equal.

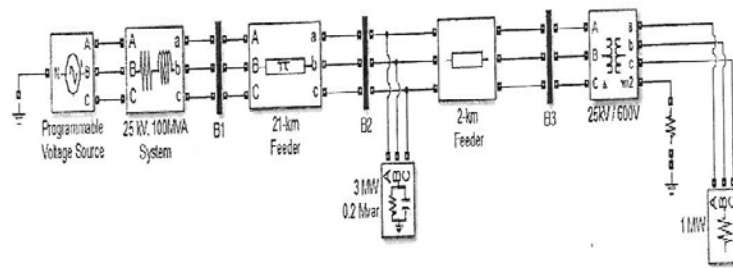

Fig. 1: the circuit diagram of sample network

General model of simulation

In figure 2 the overview of the circuit is shown which is described in following.

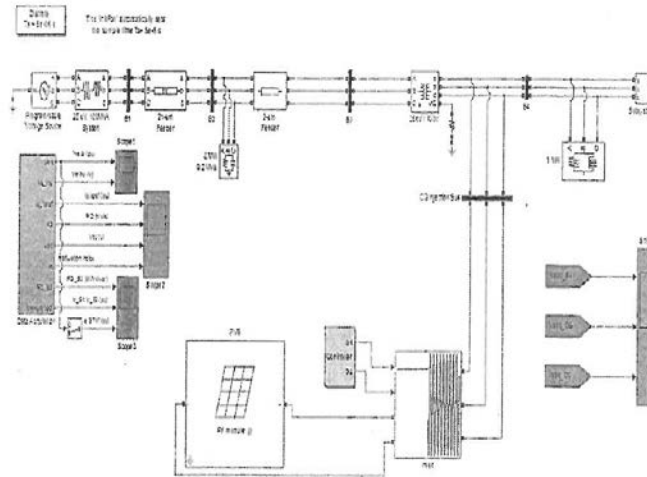

Fig. 2: the overview of the circuit

a) Compensation circuit

As it can be seen in the figure (3) the solar cell is used as the source of energy production.

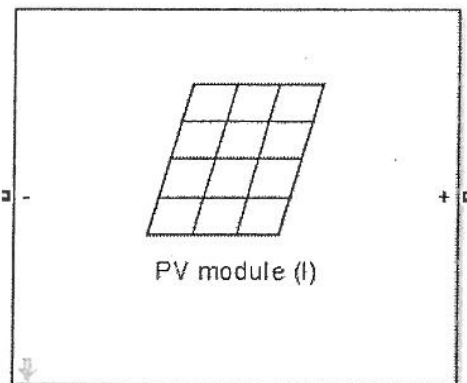

Fig. 3: solar cell

The domain of power generation of this source and other parameters of it is shown in table 1.

Table 1: parameters of solar cell

Short-circuit current	5/45
Open-circuit voltage	22/2
Current at Pmax	4/65
Voltage at Pmax	17/2

b) Inverter

Here, a DC to AC model is used which exist in the simulink of MATLAB software. In this convertor the input dc voltage was 12 volt and the output voltage was 220 volt in form of AC. The circuit of this convertor is shown in figure (4).

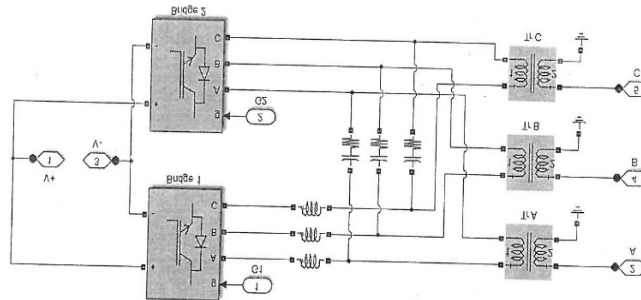

Fig. 4: the DC/AC convertor

- c) As already mentioned, a PID controller is used to inject the best amount of power which its coefficients are optimized by GSA algorithm. A PID controller which there is in MATLAB software simulink is used here. The controller circuit is shown in figure 5.

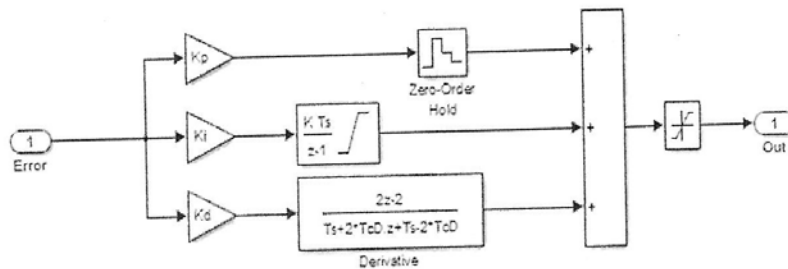

Fig. 5: controller circuit

d) Creating imbalance

As it can be seen in figure 6, for creating the imbalance of voltage in the end of feeder three single phase load is used which is applied to circuit by a switch. The amount of single phase loads is shown in table 2.

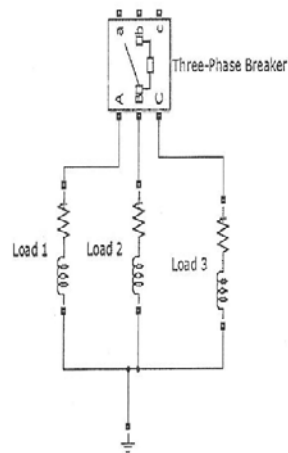

Fig. 6: imbalance single phase load

Table 2: the amount of single phase loads

	Load1	Load2	Load3
Active Power P (W)	140 Kw	80 Kw	106 Kw
Inductive reactive power	100 Kvar	60 Kvar	80 Kvar
Capacitive reactive power	-	-	-

Parameters of gravitational search algorithm

For solving the optimizing problem the PID coefficients are produced in stochastic form using GSA with 100 member's initial population. The size of archive memory is considered 100 mass. Each mass contain 3 parameter of PID coefficient. Moreover, the number of repeats is equal to 100. A part of answers resulted from solving the problem by GSA is shown in table 3. Although the provided answers are not prior to each other in terms of concept, by refer to existing knowledge in electricity industry it seems that the answers with $K_p=8$, $K_i=20$, and $K_d = 1$ are more logical than the others. The reason of the choosing is that if the coefficient gets chosen the system will have the appropriate characteristic.

Table 3: the optimized coefficient of PID controller

K_p	8
K_i	20

The result of simulation

In the figure 7 the voltage is shown per unit which is applied to network in 0.1 second by applying on imbalance based on table 2 and its effect is observed.

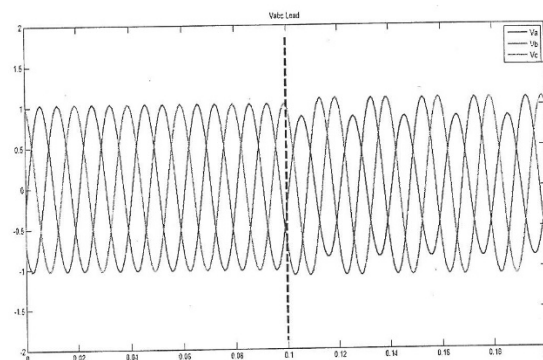

Fig. 7: the effect of imbalance load on network voltage

Now for removing the imbalance of voltage of network a photovoltaic source is used which is used for injecting the best amount of power that is need for PID controller that is optimized by GSA algorithm.

In figure 8 the voltage of source is shown after entrance of load to network. It is clear that up to 0.1 second the source does not apply any voltage to the network and since the initial values are used the form of a harmonic wave is applied to the network.

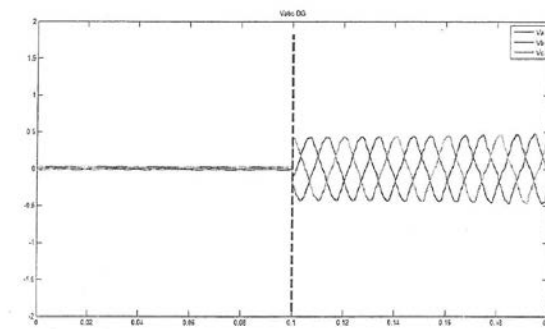

Fig. 8: the form of the wave of the source current

In figure 9 the shape of the wave of the source is shown which enters to the network in 0.1 second and after optimizing the values of PID controller with GSA algorithm it applies the least amount of harmonic to the network.

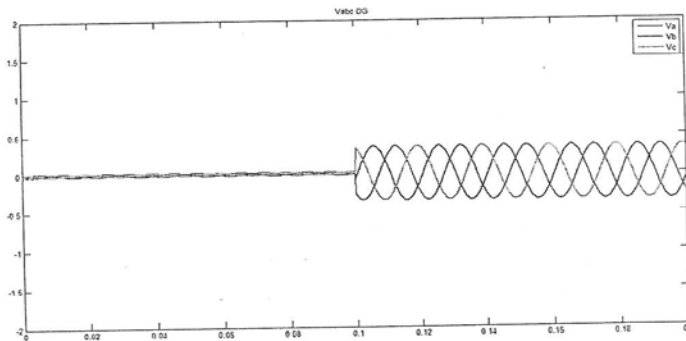

Fig. 9: the form of the voltage wave of source

In figure 10 the shape of the voltage of the network is shown which is balanced after applying the imbalance load and enter of the compensation source. It seems that the answers with the $K_d=1$, $K_i=20$, and $K_p=8$ coefficient are more logical than other answers because by choosing, the choose of the system coefficient will have appropriate characteristics.

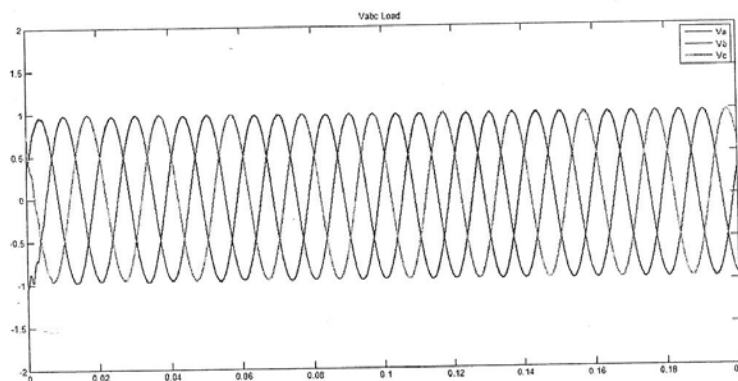

Fig. 10: the wave of the voltage after enter of source

Using the dispersed sources in addition to removing the imbalance of the voltage can provide a part of energy which is need for network and it can be said that the primer sources of dispersed production shows better and faster response against the changes of loads in network.

Conclusion

By attention to this case that balancing the of loads of phases, in comparison with creating major power plant and transporting networks, do not need much financial resources and huge equipment, the distribution companies using practical methods and technical equipments and handling the networks somehow can apply balance between voltages by dividing consumers over phases of network and installing low pressure capacitor. These solutions only can compensate the problem to a certain extent. In comparison with other actions getting done form removing the imbalance, using the dispersed power resources can provide a part of the energy which is needed for consumer in addition to removing the imbalance of voltage and it can be said that dispersed power resources show better response to changes of network.

References

- E.Rashedi, H.Nezamabadi-pour, S.Saryazdi "Gravitational Search Algorithm". March 2009
- J.D. Farmer, N.H.Ppakard and A.S.Perelson. "The immune system, adaptation, and machine learning". *Physica D* 22, 187-204. 2012.
- J.Kennedy and R.C.Eberhart, "Particle swarm optimization", *Proceedings of IEEE International Conference on Neural Networks*, Vol.4, 2013.
- K.S. Tang, K.F.Man, S.K. wong and Q.He, "Genetic algorithms and their applications". *IEEE Signal Processing Magazine* 13(6). 2014.
- M. Dorigo, V. Maniezzo, and A. Colomi, "The Ant System: optimization by a colony of cooperating agents". *IEEE Transaction on systems, Man, and Cybernetics-part B*, Vol. 26. No.1 ,2007, pp.1-13.
- Rahsedi, h , nezam abadi pur, gravitational optimization, 15th conference of Iran electricity engineering, Tehran 2007.
- S.Kirkpatrick, C.D. Gelatto and M.P. Vecchi, "Optimization by simulated annealing", *Science* 220 (4598), 671-680.2009.